

Model ECX20 - ESR20B51

- 5" - 14 gauge spun aluminum ball gold anodized
- Single sheave truck, cast aluminum revolving, non-fouling type
- 2 Bronze swivel snaps with covers per halyard
- 1 Set of halyard: #10 poly

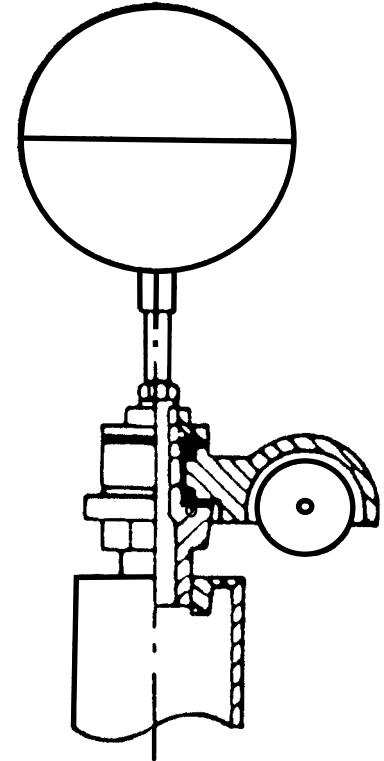

Truck Detail

- Aluminum body
- Stainless steel ball bearings
- Aluminum sheave
- Cast aluminum spindle

1 - 9" Cast aluminum cleat

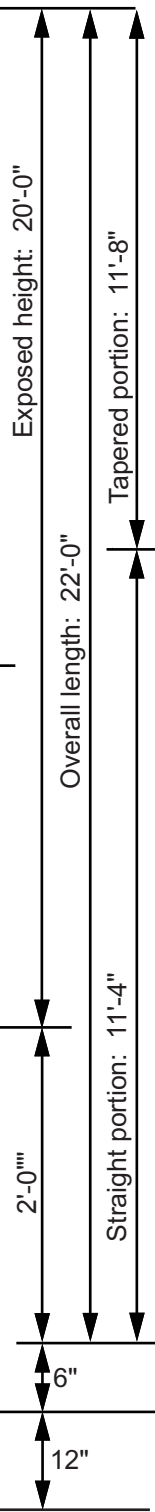

Aluminum flash collar

3000 PSI concrete

Hardwood wedges (supplied by others)

Dry sand tightly tamped after aligning pole

Foundation sleeve -16 ga hot dip galvanized steel

Steel centering wedges

1/4" Steel base plate

1/4" Steel support plate welded to grounding spike

All shafts with overall length of more than 38'-6" are shipped in two sections.

Each section matched marked for field assembly. Exposed portion of jam sleeve must be **well lubricated** prior to assembly.

1-1/2" maximum shop gap allowed for field fitting (ram for tight joint)

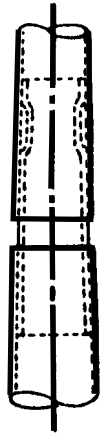

Filename: ECX20 single sheave_revolving truck.ai

Project:	Ground set tapered aluminum flagpole: ALLOY: 6063T6	FLAGPOLES ETC	Date:
Location:	Exposed height: 20'-0"	Overall height: 22'-0"	407 Hadley St.
Architect:	Ship in 1 section	Butt diameter: 5"	Holly, MI 48442
Contractor:	Top diameter: 3"	Wall thickness: .125"	(888) 735-5591
Customer:	Finish: 100 grit polish		Job: