

### Model ECA30 - ESR30C61

6" - 14 gauge spun aluminum ball  
gold anodized

Single sheave truck, cast aluminum  
revolving, non-fouling type

2 Bronze swivel snaps with covers  
per halyard

1 Set of halyard: #10 poly

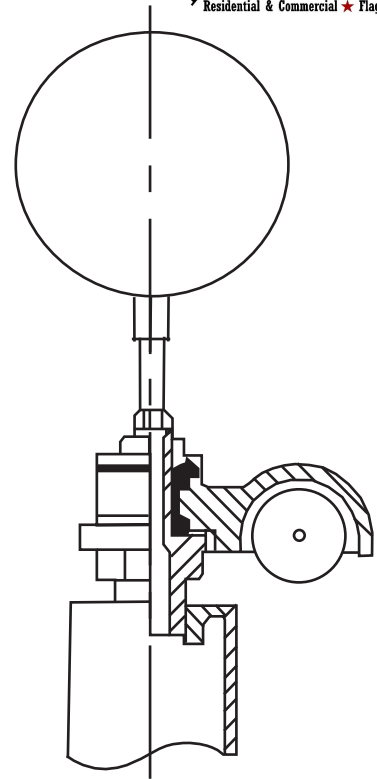

**Truck Detail**

Aluminum body  
Stainless steel ball bearings  
Aluminum sheave  
Cast aluminum spindle

1 - 9" Cast aluminum cleat

Aluminum flash collar

3000 PSI concrete

Hardwood wedges  
(supplied by others)

Dry sand tightly tamped  
after aligning pole

Foundation sleeve -16 ga  
hot dip galvanized steel

Steel centering wedges

1/4" Steel base plate

1/4" Steel support plate  
welded to grounding spike

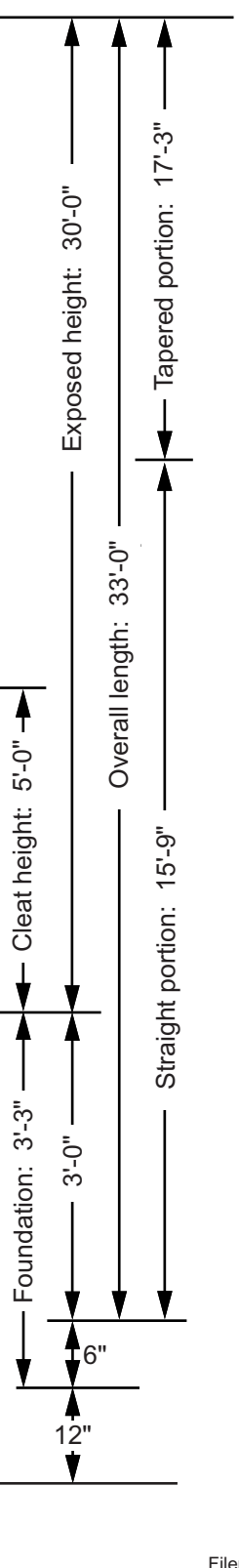

All shafts with overall length of more than 38'-6" are shipped in two sections.

Each section matched marked for field assembly. Exposed portion of jam sleeve must be **well lubricated** prior to assembly.

1-1/2" maximum shop gap allowed for field fitting (ram for tight joint)

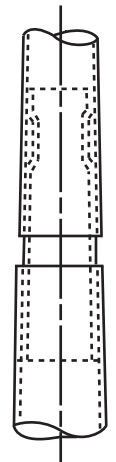

Filename: ECA30 stationary\_single sheave\_truck.ai

Project:	Ground set tapered aluminum flagpole: ALLOY: 6063T6	FLAGPOLES ETC	Date:
Location:	Exposed height: 30'-0"	Overall height: 33'-0"	Revision:
Architect:	Ships in 1 or 2 sections	Butt diameter: 6"	Holly, MI 48442
Contractor:	Top diameter: 3-1/2"	Wall thickness: .156"	(888) 735-5591
Customer:	Finish: 100 grit polish		Job: